

**AH19483**

500 series without secondary element,  
Straight outlet

**AH19482**

500 series with secondary element,  
Straight outlet

**Air Cleaner Data Sheet and  
Performance Curve**



**AH19483**  
**AH19482**



**AH19482**

# OptiAir™ Air Cleaner Data Sheet and Performance Curve

## AH19483/AH19482 500 Series - Preliminary Data

<b>Air Cleaner Model:</b>	AH19483	<b>Min CFM:</b>	58 cfm	<b>Max CFM:</b>	148 cfm	<b>Secondary Element:</b>	No
<b>Air Cleaner Model:</b>	AH19482	<b>Min CFM:</b>	65 cfm	<b>Max CFM:</b>	112 cfm	<b>Secondary Element:</b>	Yes
<b>Housing Material:</b>	Plastic	<b>Precleaner Integral:</b>	Yes	<b>Outlet:</b>	Straight		

### General Performance Data (Per ISO 5011)

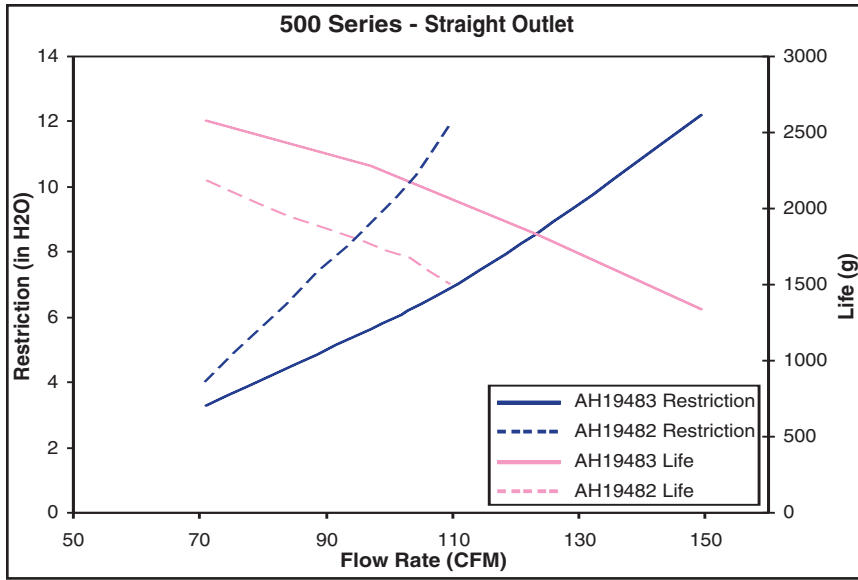

Efficiency: 99.98%

### Interpolated Data, AH19483:

Capacity		Flow Rate	
g/CFM	g/m <sup>3</sup> /min	CFM	m <sup>3</sup> /min
10	350	146	4.09
25	875	93.7	2.62

Restriction		Flow Rate	
in H <sub>2</sub> O	kPa	CFM	m <sup>3</sup> /min
6	1.49	102	2.86
8	1.99	121	3.39
10	2.49	133	3.72
12	2.99	148	4.14

### Interpolated Data, AH19482:

Capacity		Flow Rate	
g/CFM	g/m <sup>3</sup> /min	CFM	m <sup>3</sup> /min
10	350	128	3.58
25	875	82	2.30

Restriction		Flow Rate	
in H <sub>2</sub> O	kPa	CFM	m <sup>3</sup> /min
6	1.49	85	2.38
8	1.99	94	2.63
10	2.49	105	2.94
12	2.99	112	3.14

### Accessories

	Part #
Mounting Bracket P/N:	3918198S
Brackets Required:	1
Outlet Band Clamps:	3316654S
Weather Hood:	3918193S
Hump-Hose:	N/A
90° Elbow:	3316565S
90° Reducing Elbow:	N/A
Restriction Gauge:	3946326S

### Service Parts

	Part #
Primary Element:	AF26168
Magnum Primary Element:	N/A
Safety Element:	AF26166
Dust Ejection Valve:	3947091S
Cover Assembly:	3946460S

### Conversion Information

1 in H<sub>2</sub>O = 0.249 kPa  
 1 CFM = 0.028 m<sup>3</sup>/min  
 1 g/CFM = 350 g/m<sup>3</sup>/min  
 1g = 0.001 kg

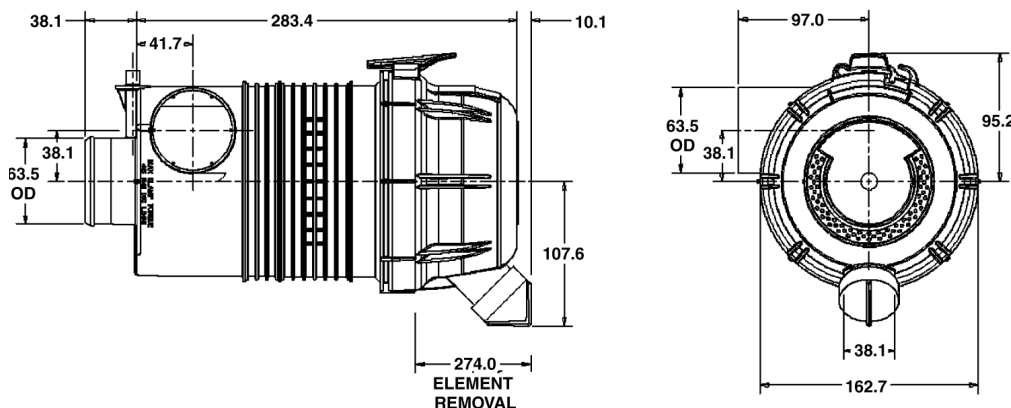

### Cover to Housing Latch Positions

3 Latch Positions

